

EFFECT OF THE DEGREE OF ROUGHNESS OF THE
ENCLOSING WALLS AND THE GEOMETRICAL
SIMPLEX OF THE LAYER ON THE STRUCTURE AND
LOSS OF HEAD IN STATIONARY AND MOVING
GRANULAR LAYERS (BEDS)

V. K. Durnov and N. M. Babushkin

UDC 532.546

A granular medium consisting of irregularly-shaped particles similar in size and with an extremely rough surface is considered.

This paper constitutes a continuation of earlier investigations published in [1].

The influence of the geometrical simplex of a layer of the kind envisaged has been studied by a number of authors [2-8], but always for a stationary layer and without proper allowance for the effects of the experimental conditions. Quantitative recommendations as to the choice of the D/d ratio when simulating layer processes differ by an order of magnitude as between different authors. In recent years Gorbis and colleagues have carried out a series of investigations [9-11], from which it follows that, during the formation of structure in a loose medium, complicated physical phenomena take place at the boundaries with the wall. The degree of influence of the ratio D/d on the development of heat- and mass-transfer processes and gas-dynamical phenomena in such cases may change substantially as a result of changes in the state of the walls, the surface properties, the shape of the particles, and so on. It was shown in [1] that the roughness of the walls had a considerable influence on the structure, not only in the region close to the wall, but also over the whole layer.

The number of investigations relating to a compact gravitating layer is extremely limited, although this type of loose medium is widely encountered in industrial processes (in shaft processes during the remelting of pig iron and nonferrous metals, the roasting of various materials, and thermal power systems).

Our experiments were carried out in the model of a shaft furnace illustrated schematically in Fig. 1. This enabled us to eliminate the influence of the variations taking place in the form factor of the fragments with varying size. The D/d ratio was varied by using shafts of different diameters. Different degrees of wall roughness were created by depositing electrotechnical graphite or fine-grained emery powder on the inner surface of the shaft. The principal dimensions of the shafts and the coefficient of friction of coke in a state of rest relative to walls of differing roughness are indicated in Table 1.

The error in determining the coefficient of friction of the material with respect to the wall amounted to $\pm 5\%$.

The porosity of the layer was determined from the bulk and apparent densities of the coke, and the hydraulic resistance was deduced by measuring the loss of head over the height of the layer and the total rate of air flow passing through the latter. The measuring errors of these quantities never exceeded $\pm 1\%$.

In order to reduce the experimental error associated with the additional reduction in coke particle size in successive tests due to the loading, moving, and unloading processes, we systematically recleaned the whole mass of material and removed the 3 mm fraction after every 8-10 experiments. The measurements showed that the number of coke particles smaller than 3 mm was in this case around 2.0-2.5%.

All-Union Scientific-Research Institute of Metallurgical Heat Technology, Sverdlovsk. Translated from *Inzhenerno-Fizicheskii Zhurnal*, Vol. 26, No. 6, pp. 1014-1023, June, 1974. Original article submitted March 26, 1973.

© 1975 Plenum Publishing Corporation, 227 West 17th Street, New York, N.Y. 10011. No part of this publication may be reproduced, stored in a retrieval system, or transmitted, in any form or by any means, electronic, mechanical, photocopying, microfilming, recording or otherwise, without written permission of the publisher. A copy of this article is available from the publisher for \$15.00.

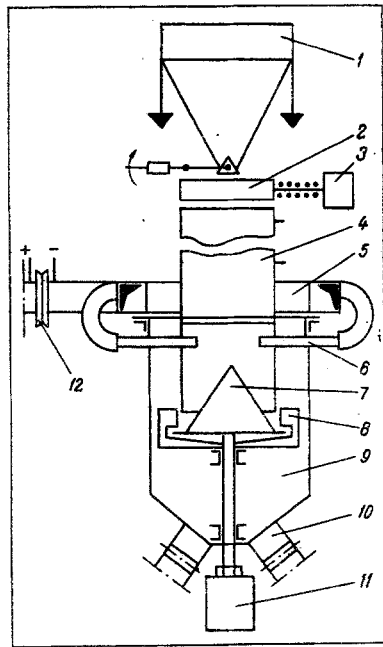

Fig. 1. Arrangement of the apparatus: 1) bunker with trap (gate); 2) mesh (screen); 3) vibrator; 4) demountable shaft with static pressure takeoff points; 5) air conduit; 6) air supply tuyeres; 7) material dissector; 8) rotating blades to remove material from the shaft; 9) receiving bunker; 10) gates for removal of material; 11) blade drive; 12) diaphragm for measuring air flow.

TABLE 1. Principal Geometrical Parameters of the Interchangeable Shafts and Coefficient of Friction between the Coke and the Wall

Type of coating and coefficient of friction on the wall	Diameter of the shaft, mm						Height of the shaft, mm
	96	120	166	220	320	400	
Graphite $f_g = 0.45$	—	1	—	1	1	—	890
Untreated steel $f_s = 0.57$	1	1	1	1	1	1	890
Fine-grained emery powder $f_e = 0.72$	—	1	1	1	1	1	890

representative results for such shafts, the number of experiments was therefore increased by comparison with shafts of larger diameters, in which the fluctuations and segregation of the material with respect to particle size in the store bunker exerted no serious influence.

In order to eliminate subjective factors associated with the manual loading of the material into the shaft, we used an intermediate bunker—screen—shaft system ("shower" loading).

During the motion of the charge allowance was made for the time taken by the transient process in which the layer passed from the stationary into the moving state [12].

Finally the whole series of experiments was randomized, which also tended to reduce the errors associated with changes in the characteristics of the loose material from one experiment to another.

The whole complex of measures just indicated greatly increased the labor involved in the experiments, but it also substantially reduced the measuring error, which ultimately proved to be one of the most important factors in making a final choice of the method of conducting the experiments.

Determination of the Mean Porosity of the Layer. Altogether we carried out 77 experiments, the results being presented in Fig. 2.

The experimental dependence of the mean porosity of the layer on the ratio D/d may be approximated by a hyperbola of the type

$$\bar{\epsilon} = \frac{a}{n} + b, \quad (1)$$

where a and b are constants.

Despite the fact that a comparatively narrow fraction of coke was employed in these experiments, during the motion of the material in the store bunker which occurred while filling or emptying the latter, we noted a fluctuation in the size distribution and segregation of the particles with respect to size in the interior of the bunker. This led to a considerable statistical scatter in the results of experiments carried out in shafts of small diameter ($D = 96-166$ mm) when the volume of material in these amounted to 3-10% of the total mass of coke taking part in the experiments. In order to obtain

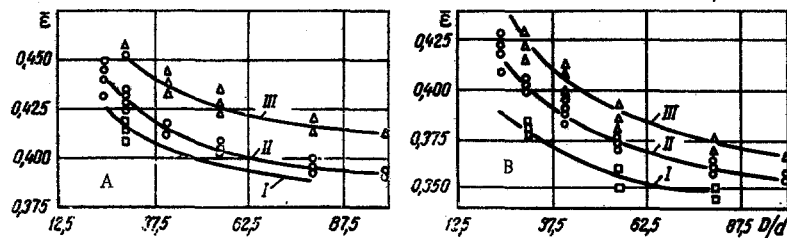

Fig. 2. Influence of the geometrical simplex of the layer (D/d) on the porosity for various degrees of roughness of the enclosing walls: I) shaft walls covered with electrotechnical graphite; II) shaft walls consisting of untreated steel; III) shaft walls covered with finely-dispersed emery; A) moving layer; B) stationary layer.

In order to elucidate the physical meaning of the constants in Eq. (1), let us consider the specific form of the latter for each experimental curve of Fig. 2. It follows from Table 2 and Eq. (1) that the coefficient b is the porosity of a layer unrestricted by walls (case of $n \rightarrow \infty$). For any finite size of the layer the mean porosity will always be greater than that of a layer unrestricted by walls, while the coefficient b may be regarded as the porosity in the central part of a layer of finite dimensions (ϵ_c).

Thus the presence of a layer with a looser structure than the main bulk close to the wall almost always leads to a certain overestimate of the mean porosity of the layer, as compared with one unrestricted by walls.

For any specified value of the increment in the mean porosity of the real layer over the porosity of a layer unrestricted by walls (or the porosity in the center of the real layer), somewhere within the range of our experiments there is always a completely specific value of D/d (Table 2). Some conclusions which, in our own view, are extremely interesting follow from these data.

In both stationary and moving layers the ratio D/d increases with increasing wall roughness for the same specified excess of the mean porosity of the layer. We find, on comparing the mean porosities of the stationary and moving layers under otherwise equal conditions, that the ratio D/d for the moving layer is always smaller than for the stationary one.

In actual fact, the greater the friction between the layer and the sides of the vessel, the more does the perturbing influence of the wall on the structure of the layer appear. On the other hand, it is well

TABLE 2. Dependence of the Geometrical Simplex on the Specified Error in the Mean Porosity and the Coefficient of Friction with the Wall

Type of wall, coef. of friction of the material with the wall in state of rest, and form of the equation	Specified error	Mean porosity of the layer		Geometrical simplex of the layer	
		stationary	moving	stationary	moving
Wall coated with electrotechnical graphite $f_g = 0.45$ $\epsilon_1 = \frac{1,50}{n} + 0,33$ $\epsilon_2 = \frac{1,35}{n} + 0,37$	0,0	0,33	0,37	∞	∞
	+3,0	0,34	0,38	150	123
	+5,0	0,35	0,39	88	71
	+8,0	0,36	0,40	56	45
	+12,0	0,37	0,42	38	29
	Untreated steel wall $f_s = 0.57$ $\epsilon_1 = \frac{2,10}{n} + 0,33$ $\epsilon_2 = \frac{1,58}{n} + 0,38$	0,0	0,33	0,38	∞
+3,0	0,34	0,39	191	143	
+5,0	0,35	0,40	124	83	
+8,0	0,36	0,41	78	53	
+12,0	0,38	0,42	47	34	
Wall coated with fine-grained emery $f_e = 0.72$ $\epsilon_1 = \frac{2,44}{n} + 0,34$ $\epsilon_2 = \frac{1,70}{n} + 0,40$	0,0	0,34	0,40	∞	∞
	+3,0	0,35	0,41	244	142
	+5,0	0,36	0,42	143	85
	+8,0	0,37	0,43	87	53
	+12,0	0,39	0,45	58	35

TABLE 3. Porosity, Number of Perturbed Rows in the Wall Region of the Layer, and Generalized Characteristic (c) of a Layer of Coke (3-5 mm Fraction), Expressed as Functions of the Coefficient of Friction between the Material and the Shaft Wall.

Type of wall and coefficient of friction between the material and the wall*	Static			In motion		
	$\Delta\varepsilon$	m	c	$\Delta\varepsilon$	m	c
Walls covered with electrotechnical graphite, $f_g = 0.45$	0,13	6	970	0,14	5	818
Untreated steel walls, $f_s = 0.57$	0,13	8	950	0,14	6	795
Walls covered with finely-dispersed emery powder, $f_e = 0.72$	0,13	10	900	0,14	7	744

*Only for a stationary layer.

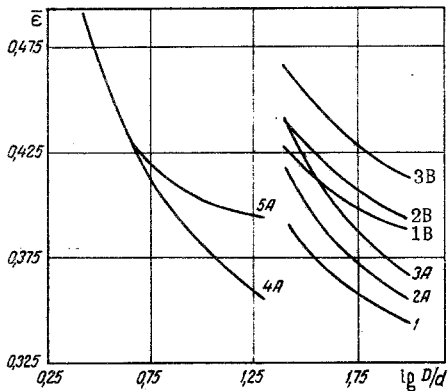

Fig. 3. Comparative data regarding the influence of the geometrical simplex of the layer on the mean porosity: 1A-3A) stationary layer, our own data; 1B-3B) moving layer, our own data; 4A) from [6, 7]; 5A) from [4].

granules of regular shape and a steel wall (curve 4A) there is a substantial change in porosity for $D/d \geq 20$. Under the conditions of our present experiments this relationship appears still more sharply (curves 1A-3A and 1B-3B).

Thus, in view of the great variety of properties characterizing these loose media and enclosing walls which are most frequently encountered in industrial installations, no unique recommendations can be made as to the choice of D/d ratio when simulating the processes under laboratory conditions; the specific conditions have to be considered every time.

It is of particular interest to determine the thickness and porosity of the layer next to the wall. Using the semiempirical equation of Verman and Banerjee, Aerov and Todes derived an equation for a cylindrical shaft, relating the mean porosity of the layer to the porosity in the peripheral and central regions, the geometrical simplex of the layer, and the thickness of the boundary region (layer next to the wall) [14]:

$$\bar{\varepsilon} = \varepsilon_c + \Delta\varepsilon \left[1 - \left(\frac{n-m}{n} \right)^2 \right] \dots, \quad (2)$$

here $\Delta\varepsilon = \varepsilon_w - \varepsilon_c$. By comparing Eqs. (1) and (2) we find

$$\Delta\varepsilon \left[1 - \left(\frac{n-m}{n} \right)^2 \right] = \frac{a}{n}. \quad (3)$$

known that the coefficient of friction is always greater in motion than in a state of rest. It is thus reasonable to expect that in a moving layer the structural perturbation will always appear to a lesser extent than in a stationary layer.

It follows from these same data (Table 2) that, if the mean porosity of the layer is considerably (12%) greater than that of a layer unrestricted by walls, the ratio D/d will be greater still - of the order of 30-50.

The absolute value of the porosity in the central part of the layer is directly related to the coefficient of friction between the material and the wall. The greater the coefficient of friction, the looser is the structure in the central parts of the layer. Thus the influence of the coefficient of friction between the material and the wall is not restricted to the region adjoining the wall, but affects the structure of the whole layer.

Figure 3 illustrates the results obtained in [4, 6, 7] together with our own data, from which it follows that for polished spheres and a smooth wall (curve 5A) the porosity of the layer remains practically constant for a ratio of $D/d \geq 20$. For

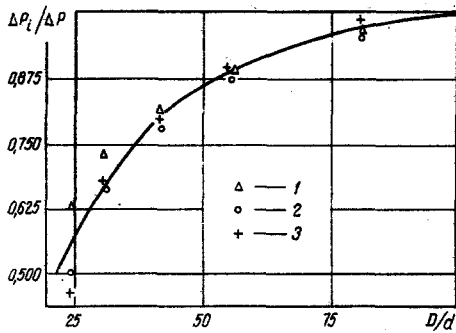

Fig. 4. Relative change in the head losses ($\Delta P_i/\Delta P$) in a layer of coke (3-5 mm fraction) for various ratios D/d : 1) shaft wall covered with electrotechnical graphite; 2) untreated steel; 3) covered with fine emery; ΔP_i head loss for various D/d ratios; ΔP the same for $D/d = 100$.

It follows from a numerical analysis of Eq. (4) that the constant a depends only slightly on n and is unrelated to $\Delta \epsilon$.

Allowing for the inequality (5) and the whole-number nature of m , we may take

$$m = 4a. \quad (6)$$

Let us calculate the value of $\Delta \epsilon$ and m from Table 2 and Eq. (4). The results of the calculation are presented in Table 3. It follows from these that the increase in the thickness of the abnormal region next to the wall is related to the increase in the coefficient of friction between the material and the wall. For a stationary layer the thickness of this region will be greater than for a moving layer. These results agree closely with the data of Table 2.

The change of porosity in the section close to the wall is greater for a moving than for a stationary layer and is independent of the coefficient of friction between the material and the wall. This conclusion confirms the results of our earlier investigations [1] obtained by direct measurements of the velocity fields of the gas phase across the radius of the layer.

The losses of pressure head over the height of the layer were measured by means of water manometers. Close to each end of the layer there is a transient gas-phase velocity field; in the lower part of the shaft this arises from the peripheral injection of gas, and in the upper part from the transitory rearrangement of the structure due to the motion of the layer; the head losses in these regions were therefore not considered.

Figure 4 illustrates the results of our experiments on passing gas through a layer of coke in shafts of various diameters with walls of various degrees of roughness. A change in the geometrical simplex over the range studied (24-100) for the same roughness of the wall is accompanied by a considerable increase in the head losses.

Analogous results were obtained in [3, 17].

On analyzing the experimental data in the form $\lambda = \varphi(\text{Re})$ we had to choose an equation of the type

$$\Delta P = \varphi(W), \quad (7)$$

which enables us to exclude the influence of D/d and the coefficient of friction between the material and the wall. The most acceptable form of the equation in our own case was one of the form [14]

$$\frac{\Delta P}{\Delta h} = \lambda \frac{c}{2g} \cdot \frac{\gamma W^2}{\epsilon^3}, \quad (8)$$

here c is an experimental quantity allowing for the properties of the particles and also the degree of roughness of the wall and the ratio D/d .

After simplifying (3) we obtain

$$m^2 - 2nm + \frac{an}{\Delta \epsilon} = 0. \quad (4)$$

The thickness of the wall part of the layer (with a structure looser than that of the center) amounts to 1-3 diameters of a typical fragment [15, 16] and depends on the coefficient of friction between the material and the wall. Thus for polished steel spheres [4] the thickness of this part of the layer is equal to the diameter of a fragment; for Raschig rings, alumina spheres, granules of fused magnesite, and corundum it amounts to two diameters [6, 7]. The fluctuations of $\Delta \epsilon$ here lie within the range

$$0.1 \leq \Delta \epsilon \leq 0.2. \quad (5)$$

It follows from Table 2 that the constant a increases regularly with increasing degree of roughness of the wall for both stationary and moving layers. This type of relationship may be associated with an increase in the number of rows next to the wall having an abnormally large porosity, or with an increasing value of $\Delta \epsilon$.

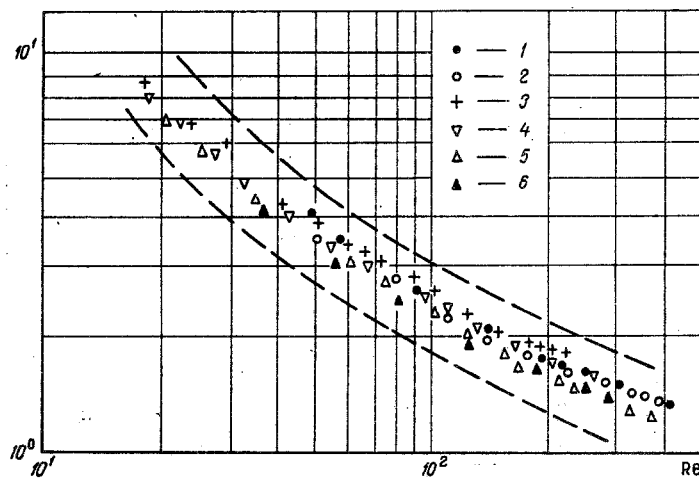

Fig. 5. Dependence of the layer resistance λ on the Reynolds number: 1, 2) $D/d = 100$, untreated steel wall, $\bar{\epsilon}_1 = 0.36$, $\bar{\epsilon}_2 = 0.39$ for the stationary and moving layers, respectively; 3, 4) $D/d = 30$, wall covered with electrotechnical graphite, $\bar{\epsilon}_3 = 0.37$, $\bar{\epsilon}_4 = 0.41$ for the stationary and moving layers, respectively; 5, 6) $D/d = 42$, wall covered with fine emery powder, $\bar{\epsilon}_5 = 0.41$, $\bar{\epsilon}_6 = 0.44$ for the stationary and moving layers, respectively. The broken lines denote the region of scatter characterizing the experimental data without allowing for the coefficient of friction between the material and the wall and the type of motion of the layer. $\lambda = \Delta P/H \cdot \epsilon^3/c \cdot 2g/W_0^2 \gamma$, $Re = 4/c \cdot W_0 \gamma/g\mu$.

Allowing for the well-known relationships

$$W_t = \frac{W}{\epsilon}, \quad d_{eq} = \frac{4\bar{\epsilon}}{c}, \quad Re = \frac{W_t d_{eq} \gamma}{\mu g}, \quad (9)$$

we may write

$$Re = \frac{4W\gamma}{c\mu g}. \quad (10)$$

In order to determine the value of c we make use of the well-known expression for the region in which viscous forces predominated

$$c = \sqrt{\frac{\Delta P \bar{\epsilon}^3}{\Delta h W \mu k}} (1 - \bar{\epsilon}). \quad (11)$$

For this purpose we carried out experiments in shafts with diameters of 120–400 mm having different degrees of roughness under both stationary and moving conditions, blowing gas through the coke layer at filtration velocities of 0.02–0.04 m/sec ($10 \leq Re \leq 20$). The results of our determination of c indicate that this quantity is related in a specific manner to the coefficient of friction between the material and the wall and also to the state of the layer (Table 3).

The results are shown in Fig. 5, after analysis in the form $\lambda = \varphi(Re)$. The experimental points all lie close to a single curve, despite the considerable variations in porosity, the geometrical simplex of the layer, and the coefficient of friction between the material and the wall. The total scatter is made up of the errors committed in determining the porosity and the coefficient of friction, respectively.

If in determining the value of c we take no account of the influence of the walls or the state of the layer (under stationary or moving conditions), either by direct measurement of the surface area and volume of individual fragments or by way of the equivalent diameter of a fragment, the scatter in the experimental data will be several times greater than the error just indicated (Fig. 5).

The results so obtained (relating to the blowing of a granular layer in model form) will depend neither on the roughness of the walls, nor on the ratio D/d , nor on the state of the layer, although by themselves these conditions have a considerable influence on the structure and loss of head.

However, if we wish to transfer the results from the model to the real sample, the properties of the particle (shape, internal porosity, surface roughness) should be identical to those of the sample. This requirement arises from the well-known fact that for porous media the hydraulic resistance of the layer is controlled by the structure and properties of the porous space, which cannot be analytically calculated from the original characteristics of the layer.

When, for any particular reason, it is impossible to determine the generalized characteristic of the layer c , in choosing the simulation parameters it is essential that the geometrical simplex of the layer should be specified with due allowance for the permissible error (tolerance) of the parameter under discussion. Thus, for example, by extrapolating the results of Figs. 2 and 4 it may be shown that increasing D/d above 100 is undesirable, since the expected change in the parameter under consideration due to this factor (in the present case the resistance of the layer) will lie within the range of the experimental error arising from the changes taking place in the characteristics of the layer from one experiment to another. However, in every case the recommended D/d ratio will be greater for the layer under discussion than for smooth spheres.

In conclusion, it should be noted that the foregoing laws will remain valid when studying heat- and mass-transfer processes in similar layers.

NOTATION

D	is the diameter of the layer;
d	is the particle size;
$n = D/d$	is the geometrical simplex of the layer;
ϵ	is the porosity;
δ	is the thickness of the boundary layer (close to the wall);
m	is the number of rows with changed structure ($m = 2\delta/d$);
ΔP	is the loss of head;
h	is the height of the layer;
λ	is the aerodynamic resistance of the layer;
f	is the coefficient of friction between the material and the wall;
c	is the generalized characteristic of the layer allowing for the shape, size, and air-permeated surface area of the particle and the structure of unit volume of the layer;
γ	is the density;
W	is the flow velocity referred to the total cross section of the layer;
Re	is the Reynolds number;
μ	is the dynamic viscosity;
k	is the Koseni-Carman constant;
g	is the gravitational acceleration.

Subscripts

c	denotes the central part of the layer;
w	denotes the wall part of the layer;
s	denotes the untreated steel wall;
g	denotes the wall coated with electrotechnical graphite;
e	denotes the wall coated with fine-grained emery powder;
eq	denotes the equivalent value;
t	denotes the true value;
i	denotes the current value;
1	denotes the stationary layer;
2	denotes the moving layer.

LITERATURE CITED

1. V. K. Durnov and V. N. Timofeev, *Inzh.-Fiz. Zh.*, **22**, No. 1, 107 (1972).
2. S. S. Fernes, *Domez*, No. 8, 74 (1932); No. 9, 62 (1932) (abs.).
3. G. K. Boreskov and L. G. Ritter, *Khim. Prom.*, No. 6, 5 (1946).
4. N. M. Zhavoronkov, M. É. Aérov, and N. N. Umnik, *Zh. Fiz. Khim.*, **23**, No. 3, 342 (1949).
5. A. N. Chernyatin, *Trans. of the Ural Polytechnic Institute [in Russian]*, No. 73, Metallurgizdat (1958).

6. P. C. Carman, *Trans. Inst. Chem. Eng. L.*, 15, 150 (1937); 16, 168 (1938).
7. M. Leva, *Chem. Eng.*, 64, No. 9, 245 (1967).
8. M. Leva and M. Grummer, *Chem. Eng. Progr.*, 43, No. 12, 713 (1947).
9. Z. R. Gorbis and V. A. Kalender'yan, *Teploénergetika*, No. 1, 75 (1962).
10. Z. R. Gorbis and V. A. Kalender'yan, *ibid.*, No. 11, 84 (1962).
11. Z. R. Gorbis, *Heat Transfer and Hydromechanics of Dispersed Through Flows* [in Russian], Énergiya, Moscow (1970).
12. V. K. Durnov, *Scientific Transactions of the All-Union Scientific-Research Institute of Metallurgical Heat Technology* [in Russian], Vol. 20, Metallurgiya (1970).
13. L. C. Verman and Banerjee, *Nature*, 157, 584 (1964).
14. M. É. Aérov and O. M. Todes, *Hydraulic and Thermal Foundations of the Operation of Systems Incorporating Stationary and Fluidized Granular Beds* [in Russian], Khimiya, Leningrad (1968).
15. L. H. S. Reblee, R. M. Baird, and J. W. Tierney, *Am. Inst. Chem. Eng. J.*, 4, No. 4, 460 (1958).
16. M. Kimura, K. Mawa, and T. Kaneda, *Chem. Eng. Japan*, 19, 397 (1955).
17. P. N. Grekov, *Izv. VUZ, Chernaya Metal.*, No. 9, 39 (1965).